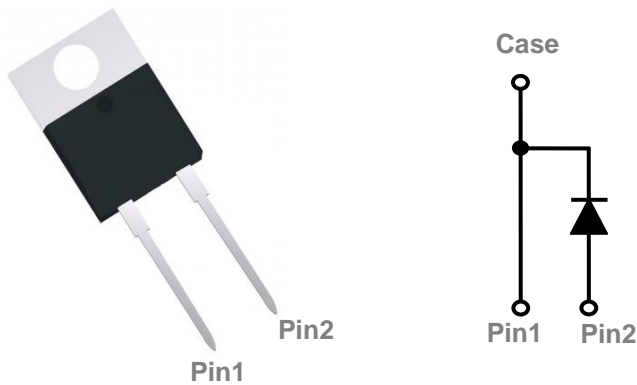


### General Description

These 650V high performance series of SiC schottky diodes are using the most advanced technology to suit for high frequency and high efficiency power systems with extreme low reverse recovery charge and can be stand up to 175°C maximum junction temperature.

$V_{BR}$	$I_F (T_C = 150^\circ\text{C})$	$Q_C$
650V	6A	18nC

### TO220-2L Pin Configuration



### Features

- 650V , 6A , 175°C junction temperature
- Extremely fast switching
- Ultra Low Reverse Recovery Current
- Positive temperature coefficient
- Green device available

### Applications

- Switching mode power supplies
- Motor drives
- Power Converters
- PFC, Power factor correction

### Absolute Maximum Ratings ( $T_C=25^\circ\text{C}$ unless otherwise noted)

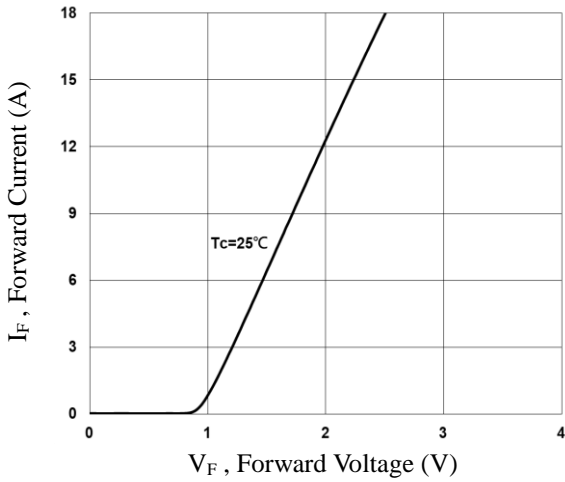
Symbol	Parameter	Rating	Units
$V_R$	DC Peak Reverse Voltage, $T_J=25^\circ\text{C}$	650	V
$V_{RRM}$	Repetitive Peak Reverse Voltage, $T_J=25^\circ\text{C}$	650	V
$V_{RSM}$	Surge Peak Reverse Voltage, $T_J=25^\circ\text{C}$	650	V
$I_F$	Continuous Forward Current, $T_C=25^\circ\text{C}$	18	A
	Continuous Forward Current, $T_C=150^\circ\text{C}$	6	A
$I_{FSM}$	Non-Repetitive Forward Surge current $T_C = 25^\circ\text{C}$ , $T_P=10\text{ms}$ Half Sine Pulse	48	A
$T_J$	Maximum operating Junction Temperature Range	175	$^\circ\text{C}$
$T_{STG}$	Storage Temperature Range	-55 to 175	$^\circ\text{C}$

### Thermal Characteristics

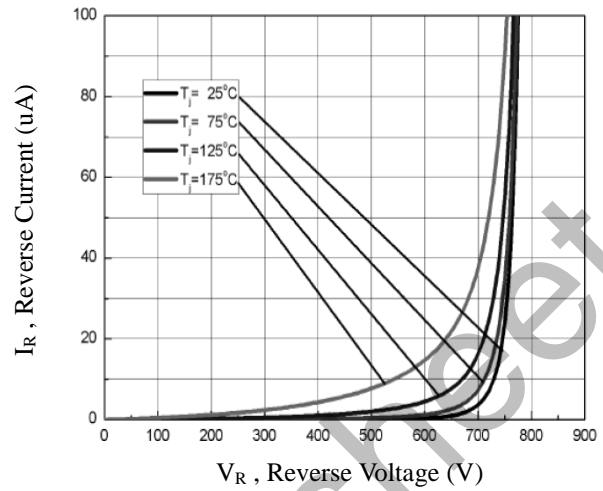
Symbol	Parameter	Typ.	Max.	Unit
$R_{\theta JC}$	Thermal Resistance Junction to Case	---	2.1	$^\circ\text{C}/\text{W}$

**Electrical Characteristics (T<sub>J</sub>=25 °C, unless otherwise noted)**

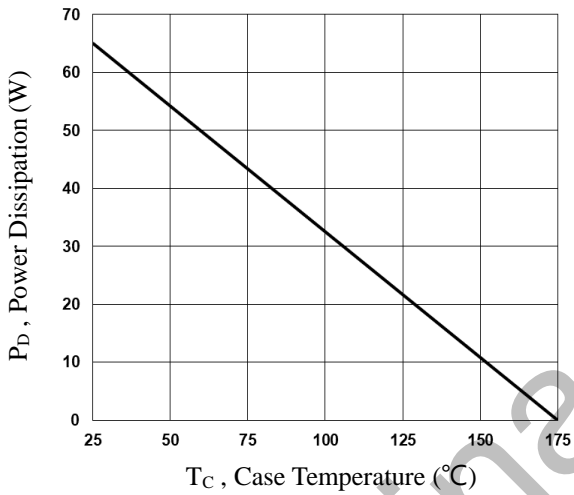
Symbol	Parameter	Conditions	Min.	Typ.	Max.	Unit
VDC	DC Blocking Voltage	I <sub>R</sub> =100μA , T <sub>J</sub> =25°C	650	---	---	V
V <sub>F</sub>	Forward Voltage	I <sub>F</sub> =6A , T <sub>J</sub> =25°C	---	1.5	1.8	V
		I <sub>F</sub> =6A , T <sub>J</sub> =150°C	---	1.9	2.2	V
I <sub>R</sub>	Reverse Current	V <sub>R</sub> =650V , T <sub>J</sub> =25°C	---	---	30	uA
		V <sub>R</sub> =650V , T <sub>J</sub> =175°C	---	---	160	uA
Q <sub>C</sub>	Total Capacitive Charge	V <sub>R</sub> =400V, I <sub>F</sub> =6A di/dt=300A/us, T <sub>J</sub> =25°C	---	18	---	nC
C	Total Capacitance	V <sub>R</sub> =10V, f=1MHz	---	115	---	pF
		V <sub>R</sub> =300V, f=1MHz	---	38.5	---	
		V <sub>R</sub> =600V, f=1MHz	---	38	---	



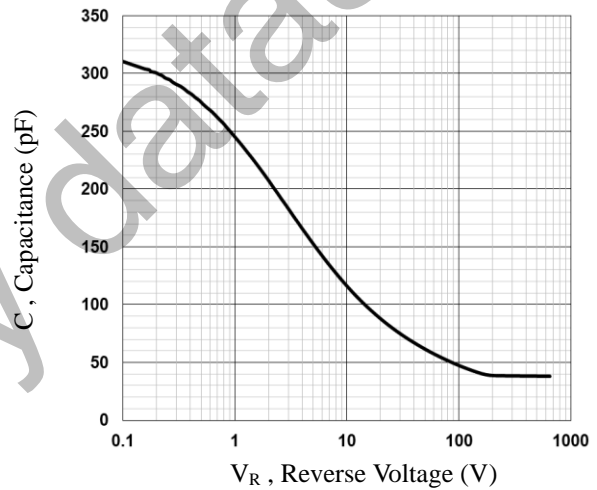
**Fig.1 Forward Characteristics**



**Fig.2 Reverse Characteristics**

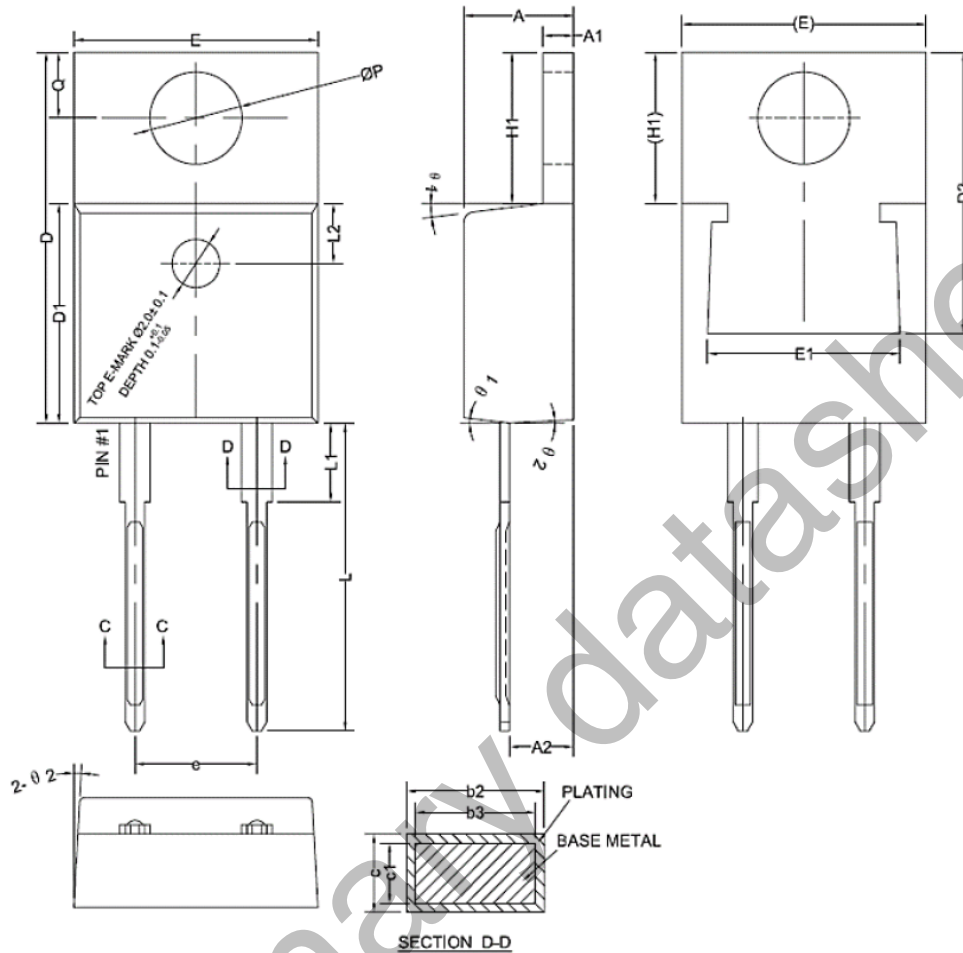


**Fig.3 Power Dissipation**



**Fig.4 Capacitance Characteristics**

**TO220-2L PACKAGE INFORMATION**



SYMBOL	mm			SYMBOL	mm		
	MIN	NOM	MAX		MIN	NOM	MAX
A	4.35	4.55	4.75	E	9.85	10.10	10.30
A1	1.25	---	1.35	E1	7.60	---	8.20
A2	2.2	2.6	2.8	e	4.90	5.10	5.20
b2	1.15	1.32	1.45	H1	6.35	6.45	6.55
b3	1.12	---	1.42	L	12.70	---	13.20
c	0.45	0.55	0.60	L1	2.80	---	3.40
c1	0.42	---	0.57	ØP	3.30	3.60	3.85
D	15.15	15.50	16.00	Q	2.80	---	2.95
D1	9.05	9.15	9.25	θ1	5°	7°	9°
D2	12.20	---	14.00	θ1	1°	3°	5°