

## General Description

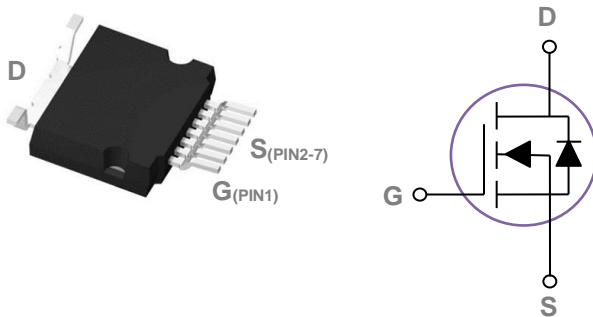
These N-Channel enhancement mode power field effect transistors are using silicon carbide technology. This advanced technology has been especially tailored to minimize on-state resistance, provide superior switching performance, and withstand high energy pulse in the avalanche and commutation mode. These devices are well suited for high efficiency fast switching applications.

BVDSS	$R_{DS(ON)(typ)}$	ID
1200V	40mΩ	45A

## Features

- 1200V,45A,  $R_{DS(ON)(typ)} = 40m\Omega @ V_{GS} = 18V$
- Improved  $dv/dt$  capability
- Fast switching
- Green Device Available

## T2PAK Pin Configuration



## Applications

- SMPS
- Solar Inverters
- Renewable energy
- EV battery chargers

## Absolute Maximum Ratings $T_c=25^\circ C$ unless otherwise noted

Symbol	Parameter	Rating	Units
$V_{DS}$	Drain-Source Voltage	1200	V
$V_{GS}$	Gate-Source Voltage	+22/-10	V
$I_D$	Drain Current – Continuous ( $T_c=25^\circ C$ )	45	A
	Drain Current – Continuous ( $T_c=100^\circ C$ )	32	A
$I_{DM}$	Drain Current – Pulsed <sup>1</sup>	112	A
$P_D$	Power Dissipation ( $T_c=25^\circ C$ )	250	W
	Power Dissipation – Derate above $25^\circ C$	1.67	W/ $^\circ C$
$T_{STG}$	Storage Temperature Range	-55 to 175	$^\circ C$
$T_J$	Operating Junction Temperature Range	-55 to 175	$^\circ C$

## Thermal Characteristics

Symbol	Parameter	Typ.	Max.	Unit
$R_{\theta JC}$	Thermal Resistance Junction to Case	0.6	---	$^\circ C/W$

**Electrical Characteristics (T<sub>J</sub>=25 °C, unless otherwise noted)**
**Off Characteristics**

Symbol	Parameter	Conditions	Min.	Typ.	Max.	Unit
BV <sub>DSS</sub>	Drain-Source Breakdown Voltage	V <sub>GS</sub> =0V, I <sub>D</sub> =100μA	1200	---	---	V
I <sub>DSS</sub>	Drain-Source Leakage Current	V <sub>DS</sub> =1200V, V <sub>GS</sub> =0V, T <sub>J</sub> =25°C	---	---	10	μA
I <sub>GSS</sub>	Gate-Source Leakage Current	V <sub>GS</sub> =22V, V <sub>DS</sub> =0V	---	---	100	nA

**On Characteristics**

R <sub>DS(ON)</sub>	Static Drain-Source On-Resistance	V <sub>GS</sub> =18V, I <sub>D</sub> =30A	---	40	52	mΩ
R <sub>DS(ON)</sub>	Static Drain-Source On-Resistance	V <sub>GS</sub> =15V, I <sub>D</sub> =30A	---	55	---	mΩ
V <sub>GS(th)</sub>	Gate Threshold Voltage	V <sub>GS</sub> =V <sub>DS</sub> , I <sub>D</sub> =3mA	1.7	2.3	2.8	V

**Dynamic and switching Characteristics**

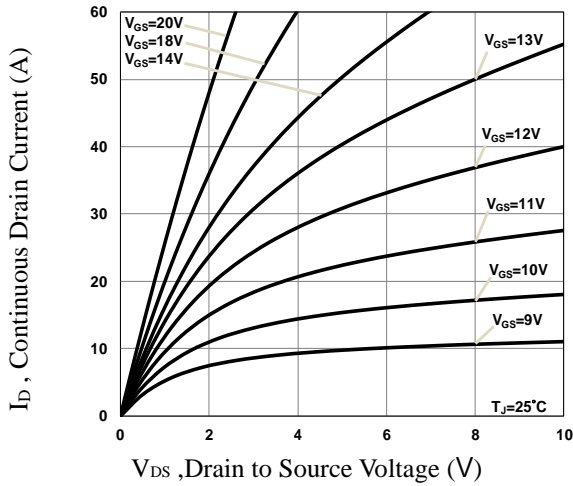
Q <sub>g</sub>	Total Gate Charge	V <sub>DS</sub> =800V, V <sub>GS</sub> =-5/18V, I <sub>DS</sub> =30A	---	82	---	nC
Q <sub>gs</sub>	Gate-Source Charge		---	17	---	
Q <sub>gd</sub>	Gate-Drain Charge		---	16.5	---	
T <sub>d(on)</sub>	Turn-On Delay Time	V <sub>DD</sub> =800V, V <sub>GS</sub> =-5/18V, R <sub>G</sub> =6Ω, I <sub>DS</sub> =30A	---	18	---	ns
T <sub>r</sub>	Rise Time		---	20	---	
T <sub>d(off)</sub>	Turn-Off Delay Time		---	25	---	
T <sub>f</sub>	Fall Time		---	30	---	
C <sub>iss</sub>	Input Capacitance	V <sub>DS</sub> =1000V, V <sub>GS</sub> =0V, F=500kHz, V <sub>AC</sub> =25mV	---	1910	---	pF
C <sub>oss</sub>	Output Capacitance		---	105	---	
C <sub>rss</sub>	Reverse Transfer Capacitance		---	5	---	
R <sub>g</sub>	Gate resistance	V <sub>GS</sub> =0V, V <sub>DS</sub> =0V, F=1MHz	---	2.3	---	Ω

**Drain-Source Diode Characteristics and Maximum Ratings**

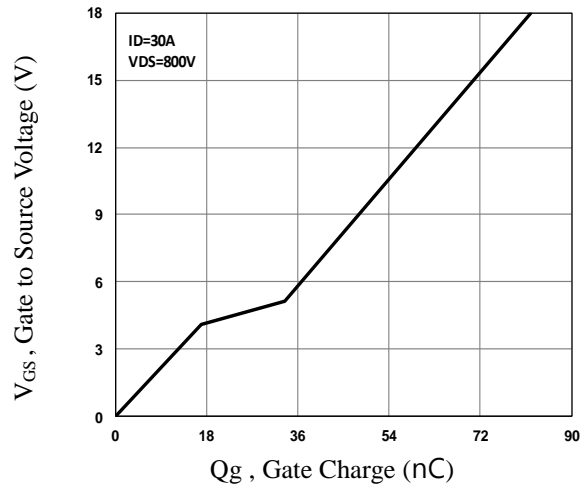
Symbol	Parameter	Conditions	Min.	Typ.	Max.	Unit
I <sub>S</sub>	Continuous Source Current	V <sub>G</sub> =V <sub>D</sub> =0V, Force Current	---	---	45	A
V <sub>SD</sub>	Diode Forward Voltage	V <sub>GS</sub> =-5V, I <sub>S</sub> =30A, T <sub>J</sub> =25°C	---	4.1	---	V
t <sub>rr</sub>	Reverse Recovery Time	V <sub>R</sub> =400V, I <sub>S</sub> =30A	---	48	---	ns
Q <sub>rr</sub>	Reverse Recovery Charge	di/dt=300A/μs, T <sub>J</sub> =25°C	---	108	---	nC

Note :

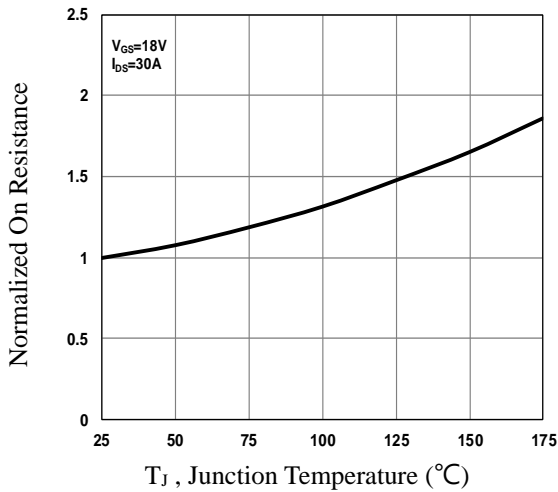
1. Repetitive Rating : Pulsed width limited by maximum junction temperature.
2. The data tested by pulsed , pulse width ≤ 300μs , duty cycle ≤ 2%.



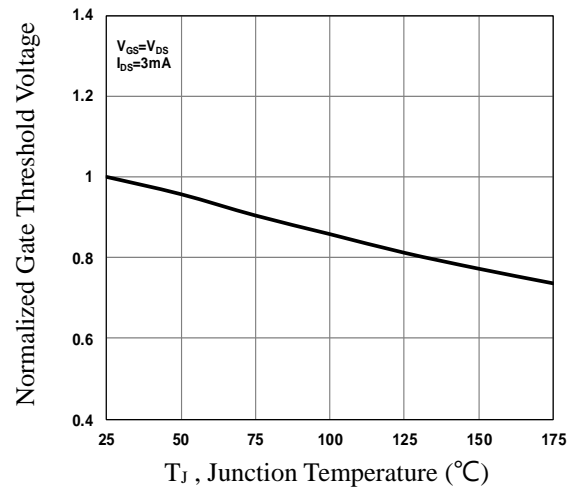
**Fig.1 Typical Output Characteristics**



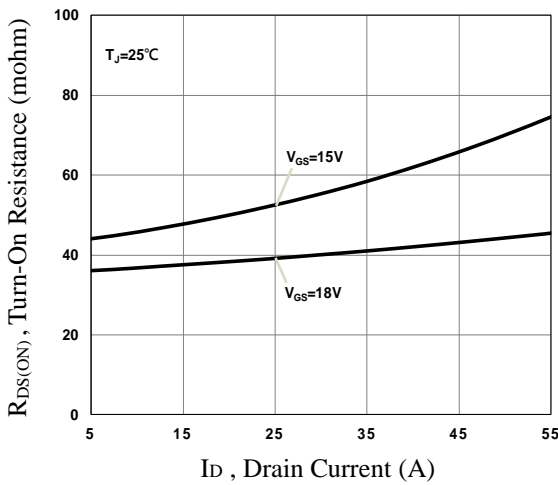
**Fig.2 Gate Charge Characteristics**



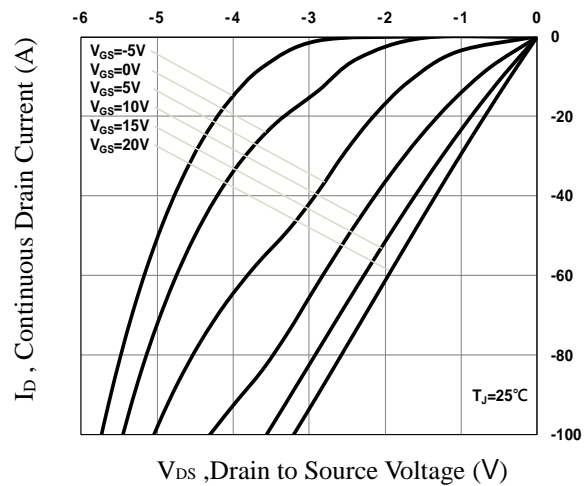
**Fig.3 Normalized RDS(on) vs. TJ**



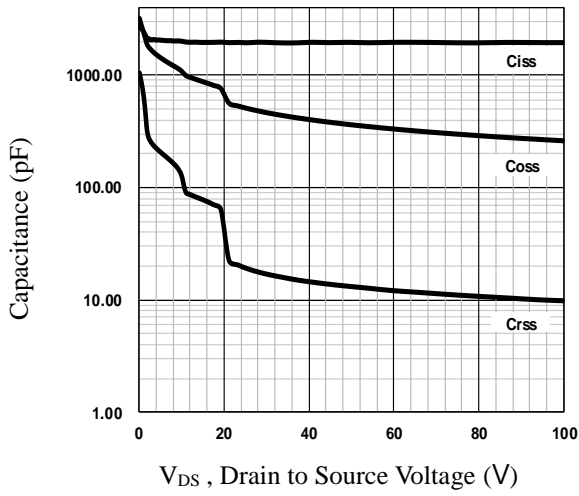
**Fig.4 Normalized V<sub>th</sub> vs. TJ**



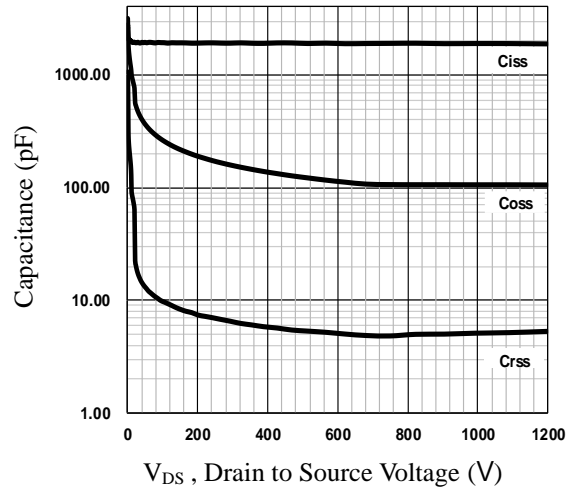
**Fig.5 Turn-On Resistance vs. ID**



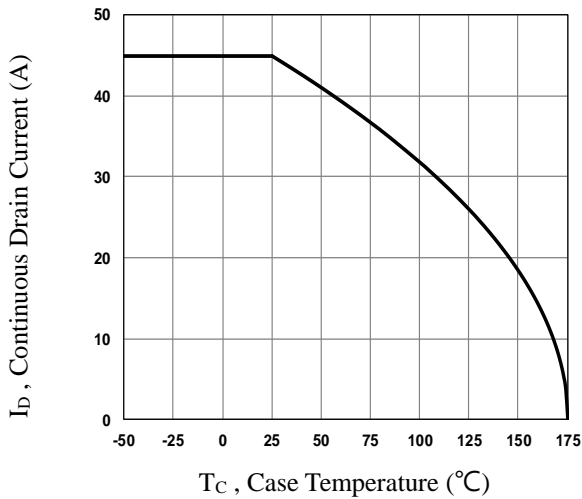
**Fig.6 3rd Quadrant Characteristic**



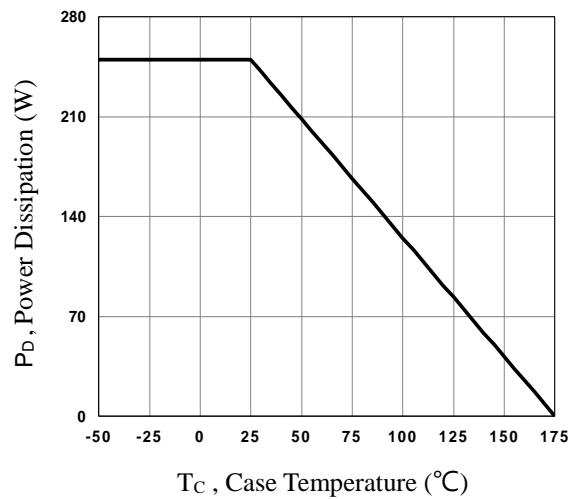
**Fig.7 Capacitance Characteristics**



**Fig.8 Capacitance Characteristics**

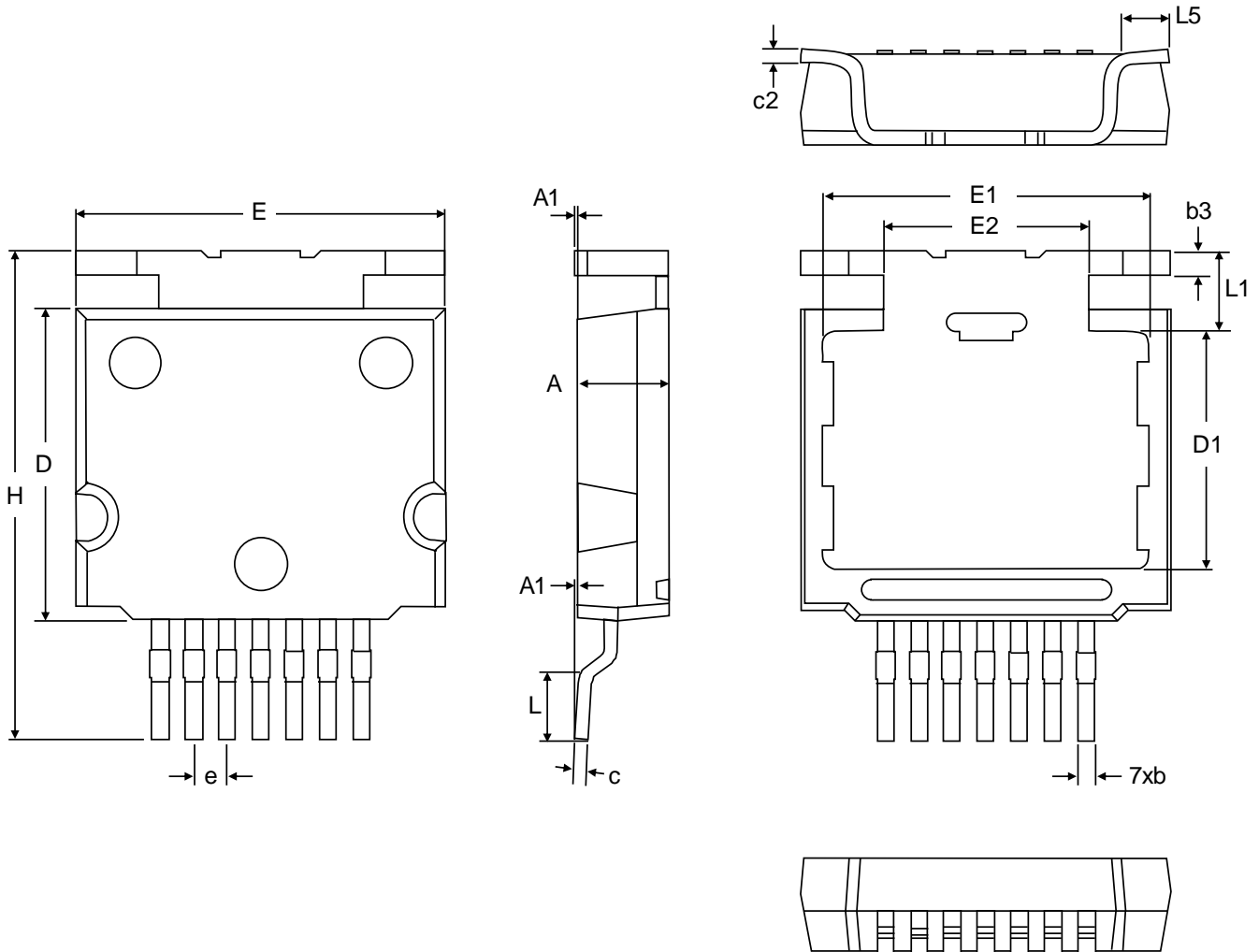


**Fig.9 Continuous Drain Current vs.  $T_c$**



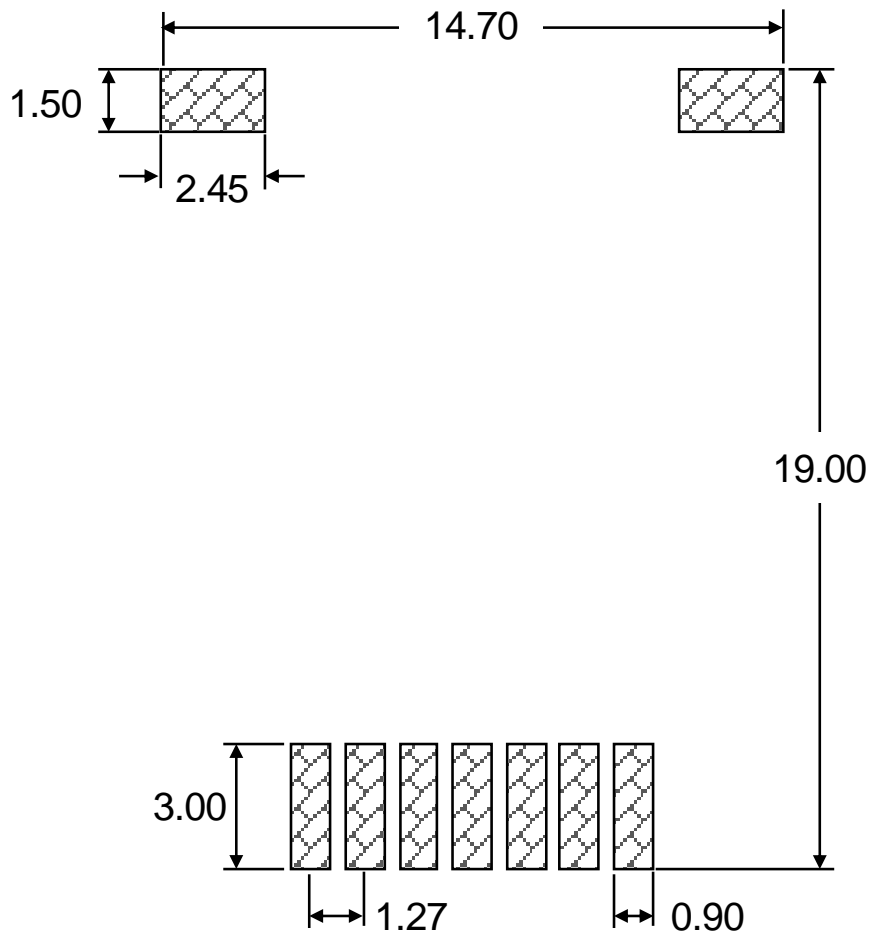
**Fig.10 Power Dissipation Derating vs.  $T_c$**

## T2PAK PACKAGE INFORMATION



Symbol	Dimensions In Millimeters		Symbol	Dimensions In Millimeters	
	MIN	MAX		MIN	MAX
A	3.40	3.60	E	13.90	14.10
A1	0.00	0.25	E1	12.30	12.50
b	0.50	0.70	E2	7.75	7.85
b3	0.80	1.00	e	1.27BSC	
c	0.40	0.60	H	18.00	19.00
c2	0.40	0.60	L	2.30	2.75
D	11.70	12.00	L1	3.05NOM	
D1	8.80	9.10	L5	1.70	2.15

### T2PAK RECOMMENDED LAND PATTERN



unit : mm